

FR4

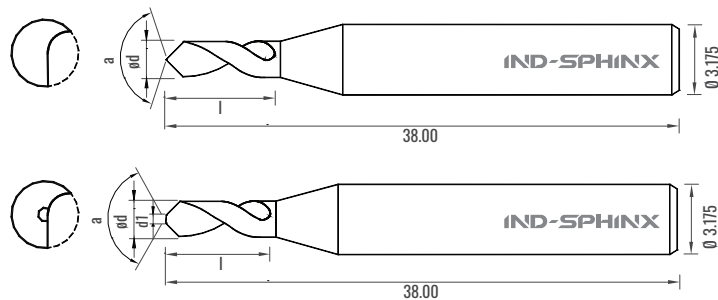

APPLICATION
V Scoring of PCBs
Partial removal of solder mask

Ø d DIAMETER	l FLUTE LENGTH	a	d1 mm
2.00	6.00	30°	0.25*
2.00	6.00	30°	-
2.00	6.00	45°	-
2.00	6.00	60°	-
3.175	8.00	90°	-
3.175	8.00	120° / 140°	-

On request : Inch / Special dimensions / Shank 3.00mm

FEATURES & BENEFITS
V Scoring on conventional drilling and routing machining

RECOMMENDED PARAMETERS		
LIP Angle	SPEED	XY FEED
a	RPM	m/min
30°	50,000 - 60,000	0.60 - 1.20
45°	48,000 - 58,000	0.70 - 1.30
60°	45,000 - 55,000	0.80 - 1.50
90°	40,000 - 50,000	1.00 - 1.80

Tabulated parameters provide guidelines which acts as starting points for optimising speeds and feeds at the user's end.

PACKING
10 tools per pack
50 tools per pack



QUALITY • PRECISION • CONSISTENCY



www.indspinx.com
customerfocus@indspinx.com